

FIBRE CEMENT PROFILED SHEETING

Choosing & Using



CJ/SfB | [(4-)] Rf9 | |
JANUARY 2019





P6 | P3

PROFILED SHEETING

Contents

- 2 Introduction
- 4 Applications
- 6 Colour range
- 8 E-Luminate
- 10 Profile 6
- 11 Profile 3
- 12 Accessories
- 14 Product selector (fold out)
- 17 GRP translucent sheets
- 18 Exposure
- 20 Installation
- 22 Ten easy steps to fixing
- 24 Working with fibre cement roofing sheets

The recommendations given in this leaflet are in accordance with BS 8219: 2001 + A1: 2013. For further information on fixing fibre cement sheets and fittings, refer to BS 8219 or contact Eternit.

Profile 3 and Profile 6

Eternit, the UK's only manufacturer of fibre cement roofing and cladding solutions, has been producing profiled sheeting for over 100 years. Today, we offer two ranges of profiled sheeting - Profile 6 and Profile 3 - to a wide range of customers. The products are differentiated by the size of corrugation in the sheets; Profile 6 having larger corrugations than Profile 3.

Both types of sheet are manufactured from a selected blend of Portland cement and water, reinforced with a mixture of both natural and synthetic fibres.

Eternit have always worked to improve safety when using our range of roofing and cladding products. Building upon over 100 years experience in the UK roofing industry we have developed a purpose designed, reinforced fibre cement sheet - Profile 6 - that meets the high standards of safety in roofing work set out in the Health and Safety Executive document 'Health and Safety in Roof Work' (HSG 33). In addition to the Profile 6 sheet, we are proud to be able to offer a complementary range of accessories that meet the same high standards of safety.

Eternit fibre cement profiled sheeting is manufactured in accordance with a quality system registered under BS EN ISO 9001.

Which profile?

The decision to use Profile 3 or Profile 6 sheets will depend largely upon the following four criteria:

- 1 The scale of the building in question.
- 2 Compatibility with any existing materials.
- 3 The distance from centre to centre of the horizontal fixing rails or purlins.
- 4 Whether or not the roofing material is to be classified as non-fragile.

Reference should therefore be made to the sheet sizes, fixing details and product data provided in this brochure before deciding which type of profiled sheeting to use.

Why choose Eternit fibre cement profiled sheeting?

- Low maintenance
- No rust, rot or corrosion
- Quick and easy to install and fix
- Highly cost effective weatherproofing
- Resistant to chemical attack
- Vapour permeability reduces condensation
- Excellent noise and thermal insulation
- Wide product and colour range

APPLICATIONS AND ADVANTAGES

Eternit fibre cement profiled sheeting has many benefits that can be used in a variety of sectors providing a cost effective solution to contractors and end users. Common sectors include:

- Agriculture
- Industrial
- Storage
- Commercial and leisure
- Education
- Housing and residential

Benefits of fibre cement vs metal

Fibre cement offers more durability than metal. Metal corrodes over time and unlike fibre cement, cannot absorb water, which will ultimately cause problems with condensation.

Fibre cement has many benefits over metal that make it a more sustainable, durable and better material in the longer term.

- Sound subduing capabilities
- High level of insulation
- Minimises condensation
- Resistant to rust, rot and corrosion

All of the above are particularly beneficial to livestock and animal welfare. For more information on this please visit eternit.co.uk

Advantages of Eternit fibre cement profiled sheets

Advantage	Profile 6	Profile 3
Moisture resistant – will not rust, rot or corrode	✓	✓
Durable – life span up to 50 years	✓	✓
Easy to install	✓	✓
Fire performance – Class A2 to BS EN 13501-1, SAA and Class 0	✓	✓
Sustainable – able to achieve up to A+ in the Green Guide	✓	✓
Variable pitches	Min. 5° pitch – can be used as vertical cladding	Min. 10° pitch – can be used as vertical cladding
Sheet size availability		
Painted and Natural Grey	1220mm, 1375mm, 1525mm, 1675mm, 1825mm, 1975mm, 2125mm, 2275mm, 2440mm, 2600mm, 2750mm, 2900mm, 3050mm	1525mm 2450mm 3050mm
Anthracite	1525mm, 1675mm, 2440mm, 2750mm, 2900mm, 3050mm	n/a
Available painted	✓	✓



COLOUR RANGE

Painted colour range

Experience gained over many years has shown that the Eternit colour range will meet the wide ranging design requirements in both rural and urban areas.

All the colours have been chosen for their ability to harmonise with the most commonly used building materials – brick, slate, stone, concrete and timber.

For more information on products and product codes, please request the Parts List brochure from infouk@etexgroup.com

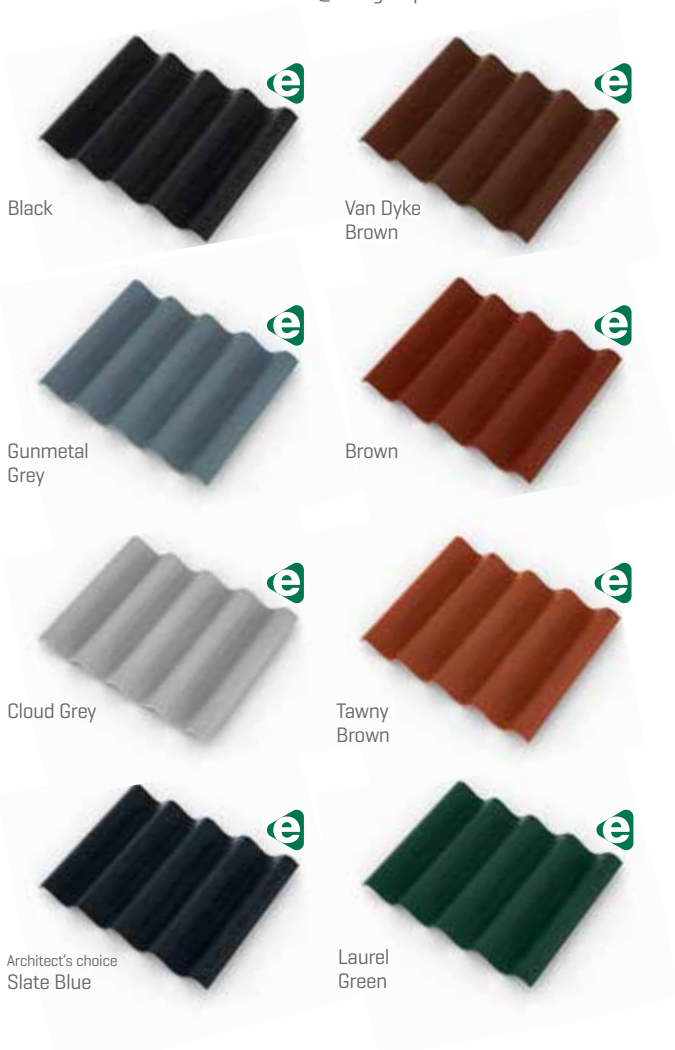

For further details on E-Luminate, please see pages 8-9.

E-Luminate™

Off-White is the colour used on the underside of E-Luminate products.



Off-White
(matt finish)

Natural Grey

Natural Grey is the standard unpainted finish for Profile 6 and Profile 3.



Natural Grey
Not suitable for E-Luminate

Matt colours

These colours are part of the standard colour range but have a matt finish.



Bracken



Sherwood

Farmscape Anthracite

Anthracite sheets have a pigmented surface layer. Together with subtle variations in tone inherent in any natural cementitious product, the appearance will blend with almost any landscape from the day the building is erected. Only available for Profile 6.



Anthracite
Not suitable for E-Luminate

For more information

Please request the Parts List brochure from infouk@etexgroup.com



NEW E-LUMINATE MAKING A BRIGHTER FUTURE



Designed to maximise light

The more we can replicate the natural environment inside a livestock building, the better it is for the animals.

At Eternit we have been investigating ways that we can help to improve the living conditions for animals whilst retaining the performance of the building and not adding additional overheads like electricity and maintenance.

E-Luminate is a technical product solution which can be used with any P6/P3 painted sheet colour option.

Please speak to your local stockist, visit eternit.co.uk or contact your Area Sales Manager.



E-Luminate in action

E-Luminate* products feature a special off-white paint coating to a painted sheet underside, researched and designed to increase light to internal livestock areas or agricultural buildings. Standard P6 and P3 painted sheets are now available with E-Luminate [POA].

A recent case study on a new stable build revealed exciting results when independent light tests were taken.

Lumens light measurement increased substantially, increasing natural light in the building by almost double.

The customer commented:

"The increased light will certainly help energy costs whilst also being an eco-friendly solution: 'most importantly Bumble is a happier pony, as an older pony suffering from laminitis, he has to be stabled for longer periods of time. In his new environment he appears more relaxed than before. It gives me the feel good factor to know I have improved his welfare'".

Independent tests proved a higher light measurement both in dark shaded areas and in the centre of the stable block.



Applications

- > Roofs & Cladding
- > Storage
- > Garages & Sheds
- > Stables



Without E-Luminate

With E-Luminate

* IMPORTANT: E-Luminate - E-Luminate is not suitable with non-painted sheets as the permeability of the surface exposed to the weather should not be any less than the permeability of the inner surface, otherwise the sheets could bow excessively as they absorb moisture from rain and possibly cracks could form. Although the specialist paint is vapour permeable, it does reduce the permeability of the products and so, when the underside of fibre cement sheets are painted, the top surface also has to be painted.

PROFILE 6

Profile 6 and safety in roof work

Profile 6 is commonly used on all types of building for both roofing and vertical cladding applications. When correctly installed, Profile 6 has been tested and classified as non-fragile, this must be considered when working to the roof safety requirements of HSG 33.

Profile 6 is a high strength fibre cement sheet with polypropylene reinforcement strips inserted along precisely engineered locations which run for the full length of the sheet to provide impact resistance.

Profile 6 sheet lengths [mm]

1220, 1375, 1525, 1675, 1825, 1975, 2125, 2275, 2440, 2600, 2750, 2900, 3050.

Farmscape lengths [mm]

1525, 1675, 2440, 2750, 2900, 3050.

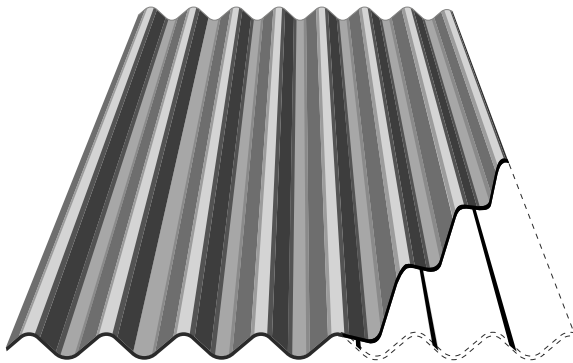

The cut-away illustration above shows the location of the polypropylene reinforcement strip inserted in precisely engineered positions in the Profile 6 sheet.

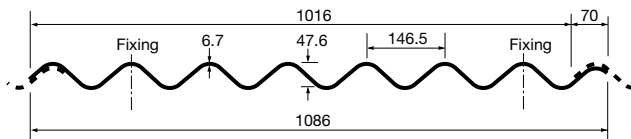

Other products

In order to ensure full compliance with HSG 33, ridges and rooflights must also be upgraded. Eternit can supply a full range of fittings to ensure that the complete roof is non-fragile – see pages 12 to 15 for details.

PROFILE 3

The lower profile of this product makes it particularly suitable for a range of domestic, smaller agricultural and light industrial buildings. It can be laid to a minimum roof pitch of 10°.

Profile 3 sheet lengths [mm]

1525, 2450, 3050

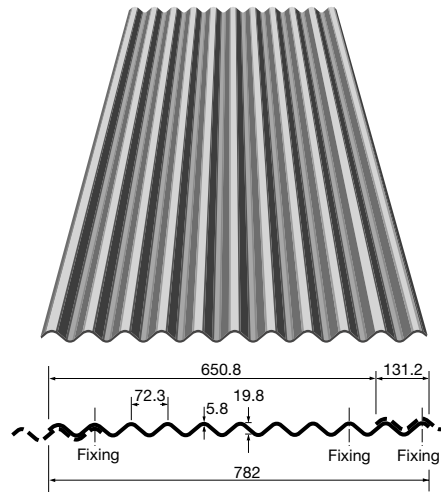

Technical data

	Profile 6	Profile 3
Overall width	1086mm	782mm
Net covering width	1016mm	650.8mm
Thickness [nominal]	6.7mm	5.8mm
Density [nominal]	1450kg/m ³	1450kg/m ³
Pitch of corrugations [nominal]	146.5mm	72.3mm
Depth of profile	47.6 mm	19.8mm
Profile height category	C	A
Side lap	70mm	131.2mm
Minimum end lap	150mm	150mm
Maximum purlin centres	1375mm	925mm
Maximum rail centres	1825mm	1225mm
Maximum unsupported overhang	350mm	250mm
Approx. weight of roof as laid, with 150mm end laps, single skin including fixings	17kg/m ²	14.5kg/m ²
Minimum roof pitch	5°	10°

ACCESSORIES

	Profile 3	Profile 6
Cranked crown sheet	N/A	Girth: 750 or 900mm Standard sizes: 5°, 7.5°, 10°, 12.5°, 15°, 17.5°, 20°, 22.5°
Ventilating crank crown	N/A	Girth: 750 or 900mm Standard sizes: 5°, 7.5°, 10°, 12.5°, 15°, 17.5°, 20°, 22.5°
Two piece close fitting ridge	Cover width: 650.8mm [adjustable]	Cover width: 1016mm [adjustable]
Two piece ventilating ridge	Cover width: 650.8mm [adjustable]	Cover width: 1016mm [adjustable]
Two piece plain wing ridge	Cover width: 650.8mm [adjustable]	Cover width: 1016mm [adjustable]
Hooded two piece ridge finial	N/A	Available

Note: Cover widths indicated make allowance for overlap

PRODUCT SELECTOR

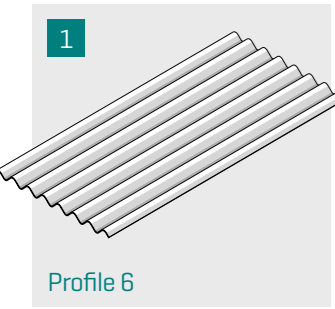

1

Profile 6

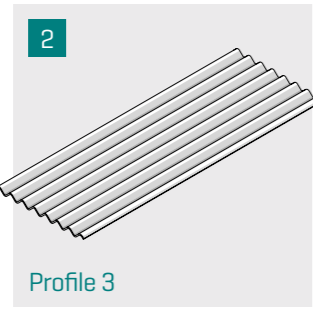

2

Profile 3



3

GRP translucent sheet*
*For P6 only

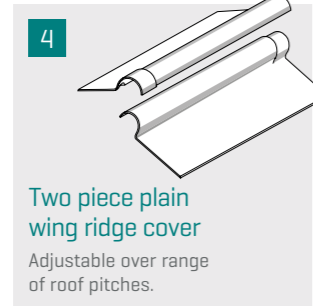

4

Two piece plain wing ridge cover
Adjustable over range of roof pitches.

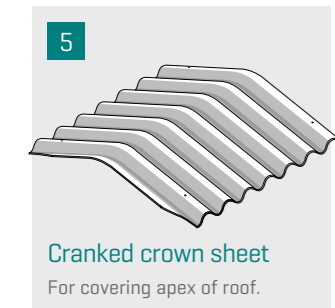

5

Cranked crown sheet
For covering apex of roof.

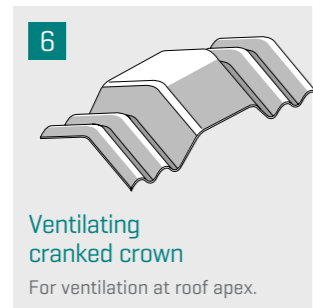

6

Ventilating cranked crown
For ventilation at roof apex.

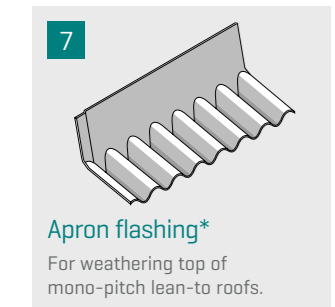

7

Apron flashing*
For weathering top of mono-pitch lean-to roofs.

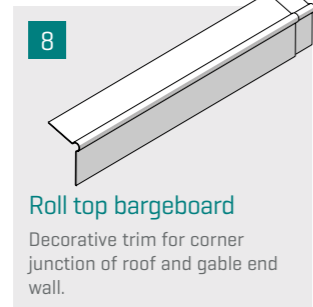

8

Roll top bargeboard
Decorative trim for corner junction of roof and gable end wall.

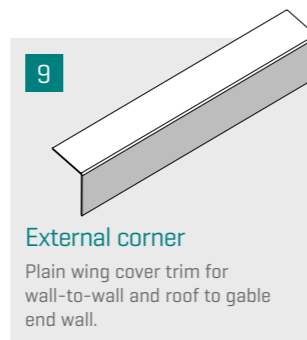
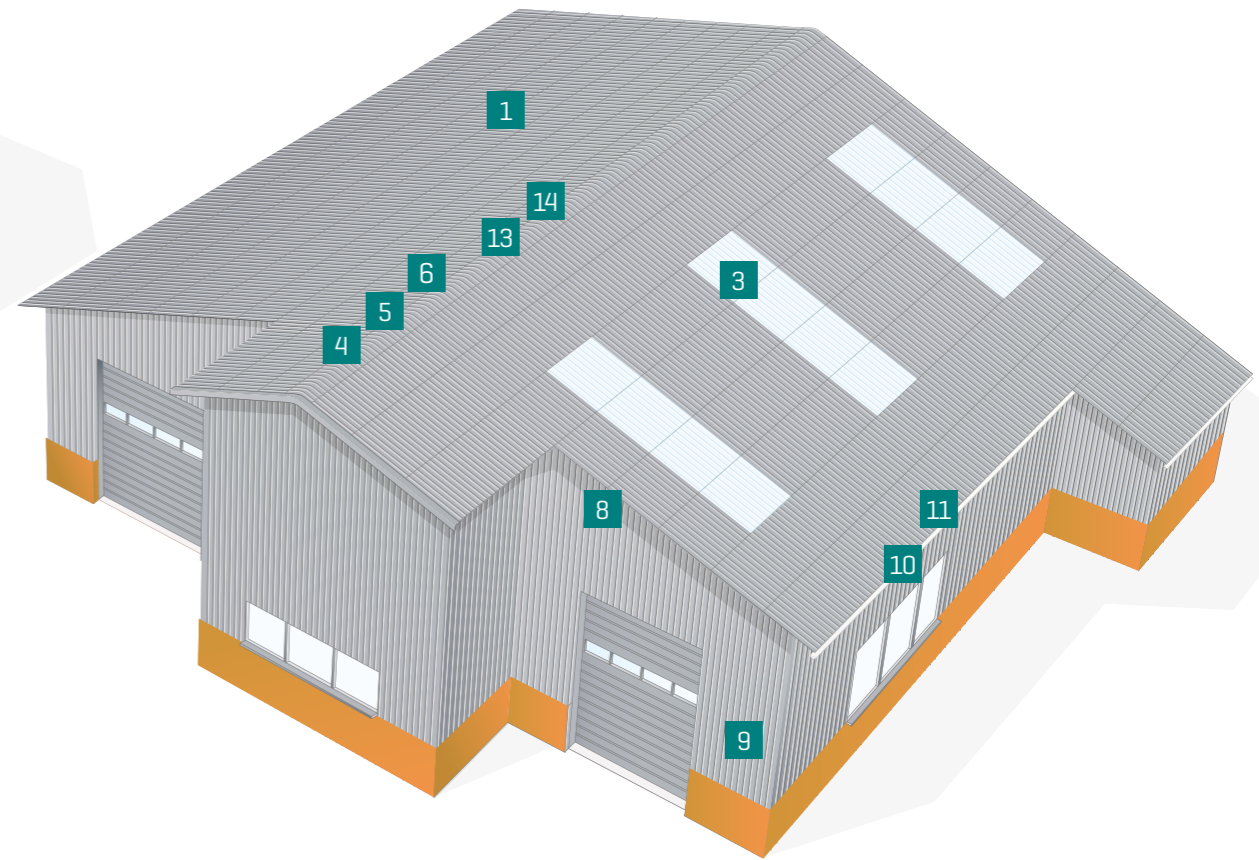
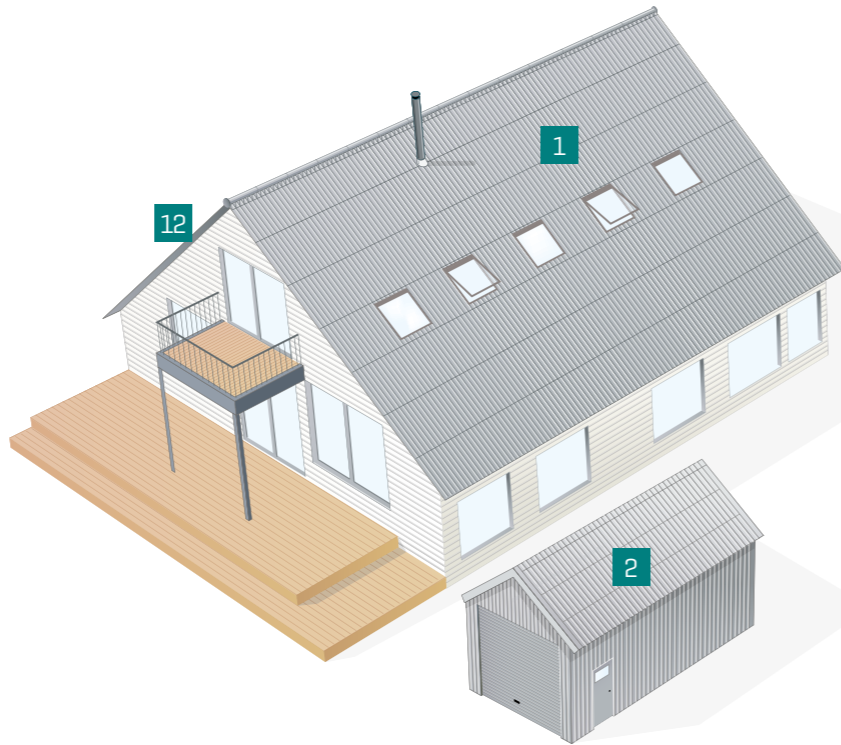

9

External corner
Plain wing cover trim for wall-to-wall and roof to gable end wall.



10

Eaves corrugation closer
For blanking off corrugation voids at eaves of roof.

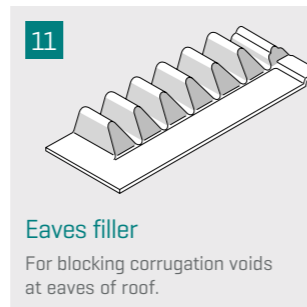

11

Eaves filler
For blocking corrugation voids at eaves of roof.

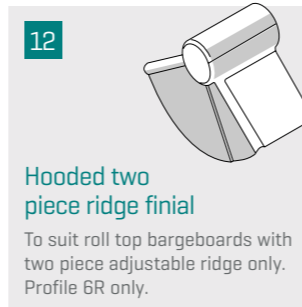

12

Hooded two piece ridge finial
To suit roll top bargeboards with two piece adjustable ridge only. Profile 6R only.



13

Two piece ventilating ridge cover
Adjustable over range of roof pitches providing natural ventilation.

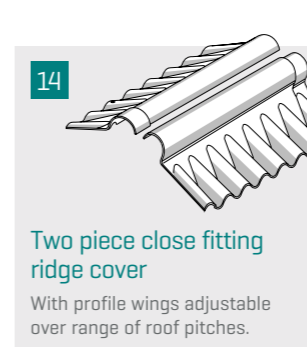

14

Two piece close fitting ridge cover
With profile wings adjustable over range of roof pitches.

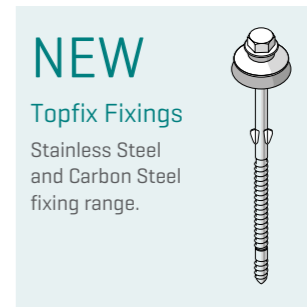

NEW

Topfix Fixings
Stainless Steel and Carbon Steel fixing range.

*Not shown

ACCESSORIES

	Profile 3	Profile 6
Eaves corrugation closure	Cover width: 650.8mm Size: 75mm [effective leg length] Handed left and right	Cover width: 1016mm Sizes: 65, 100, 150, 250mm [effective leg length] Universal
Eaves filler	Cover width: 650.8mm Handed left and right	Cover width: 1016mm Universal
Apron flashing	Cover width: 650.8mm Size: 120° Handed right	Cover width: 1016mm Size: 124° Handed left
Roll top barge board		Overall lengths: 1525mm, 2440mm, 3000mm Available in 200 x 200mm wing dimensions
External corner		Overall lengths: 1800mm, 2440mm, 3000mm Available in 200 x 200mm and 300 x 300mm wing dimensions

Request a FREE copy of our comprehensive Profiled Sheeting Parts List

Email: infouk@etexgroup.com

- ✓ P6 and P3 sheet sizes listed
- ✓ Full range of accessories
- ✓ Rainwater systems
- ✓ GRP sheets
- ✓ 13 exciting colours
- ✓ Product selector guide

The **BIGGEST** range of Profiled Sheeting in the UK

Request a **FREE** copy today



GRP TRANSLUCENT SHEETS

Advantages

- ✓ Good light transmission
- ✓ High impact resistance
- ✓ Easy installation
- ✓ Low levels of expansion and contraction
- ✓ Resistant to chemicals

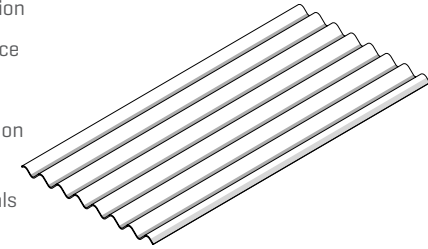

Typical GRP configurations

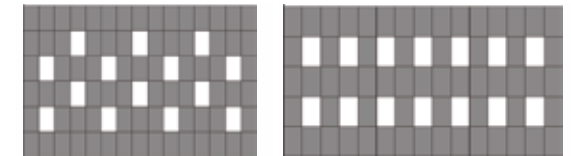

EXPOSURE

When using profiled sheeting the windloadings of a location are critical to ensure the optimal sealing requirements.

Exposure zones

Approximate wind driven rain [litres/m² per spell]

- less than 56.5
- equal to or greater than 56.5
- contact the Eternit Technical Advisory Service



Note: Map taken from BS 8219. When buildings stand above their surroundings or are situated in open country with no windbreaks, including sites on or near the coast, or on hill tops, they must be considered subject to severe exposure.

Lap

This describes how much one sheet overlaps another at either the end (end lap) or the side (side lap).

Pitch

This describes the degree to which the roof slopes.

Guidance procedure

Step 1: Exposure

Determine the expected degree of exposure by examining the adjacent map.

Step 2: Centres of support

Purlin centres for Profile 6 should be a maximum of 1375mm for a superimposed loading up to 1.89kN/m². For Profile 3, the purlins should be at 925mm maximum centres for loadings up to 1.8kN/m². There should be two fixings per sheet, per purlin. Where windloadings exceed this level, please contact the Eternit Technical Advisory Service for advice before proceeding.

Step 3: Lap and seal

Establish requirement for lapping and sealing by reference to the exposure zones map of the UK and the table below. See page 21 for sealing details.

Sheltered and moderate sites

Less than 56.5 l/m² wind driven rain per spell

Minimum Roof pitch	End lap (mm)	Lap treatment	
		End laps	Side laps
22.5° and over	150	Unsealed	Unsealed
15° and over	300	Unsealed	Unsealed
15° and over	150	Sealed	Unsealed
10° and over	150	Sealed	Sealed

Moderate and severe sites

More than 56.5 l/m² wind driven rain per spell

Minimum Roof pitch	End lap (mm)	Lap treatment	
		End laps	Side laps
25° and over	150	Unsealed	Unsealed
17.5° and over	150	Sealed	Unsealed
15° and over	150	Sealed	Sealed
10° and over	300	Sealed	Sealed

On roofs over 10° pitch where parapets might allow snow build up, 300mm double sealed end laps and single seal side laps are recommended. The minimum pitch for Profile 6 is 5°. Where slopes are between 5° and 10° the maximum slope length should be 15m with double sealed end laps and single sealed side laps.

INSTALLATION

Whilst Eternit profiled sheeting is easy to install, the following guidelines should be observed:

- The sheets should be installed smooth surface up.
- The sheets should be cut with a hand saw or slow speed reciprocating power saw.
- All fixing holes should be drilled, not punched, and should provide adequate clearance for the fastener shank (minimum 2mm).
- There should be two fixings per purlin or rail covered at the fixing points shown on pages 10 and 11.
- When using power tools in a confined area, dust extraction equipment is advisable.
- The dust and swarf generated when working with the sheets does not require any special handling requirements other than normal good housekeeping to maintain a clean working area.

Fixing

The correct fixing of a sheet is important in order to avoid premature failure, corrosion or leaks in a roof. Many factors influence the fixing of a roof, such as the purlin or rail type and the nature of the roof in question. Particularly important is the type of fastening system used and compliance with the manufacturer's recommendations.

Topfix fasteners are generally used to fix Profile 6 sheets on a roof as they provide a quick and effective one step fixing operation. Follow the recommendations of the fastener manufacturer regarding maximum roof pitch, minimum purlin thickness etc. Topfix fasteners should be installed using the recommended depth setting power tool to ensure the fasteners are correctly tightened.

Checking the topfix fasteners for tightness

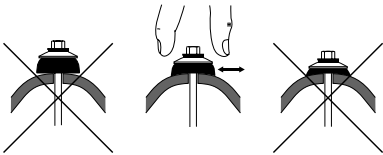

Where topfix fasteners are not used, 8mm diameter fasteners are used for Profile 6 and 6mm diameter for Profile 3. The fibre cement sheet must be pre-drilled with a 2mm clearance hole. If using drive screws, the holes must be located centrally on the purlins, if using hook or crook bolts, the holes should be 4mm upslope of the back edge of the purlin. In all instances, sealed washers and caps should be utilised to ensure adequate weather protection.

Overhangs

Sufficient overhangs must be allowed at the eaves to ensure that rainwater discharges into the gutter. Verges must be overhung by one complete corrugation unless a bargeboard is used.

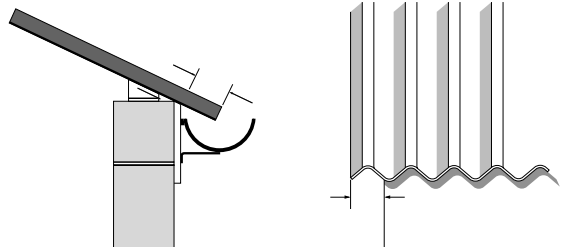

Side Laps

Sealing

Where appropriate, butyl strip sealant should be positioned as shown. Use 8mm diameter butyl strip for Profile 6 and 6mm butyl strip for Profile 3.

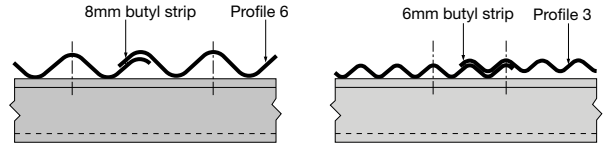

End Laps

The minimum end lap for either Profile 3 or Profile 6 is 150mm, fixed as shown in the section below.

Where double sealing is necessary with 300mm endlaps, the second butyl strip should be positioned 100-200mm below the fixing.

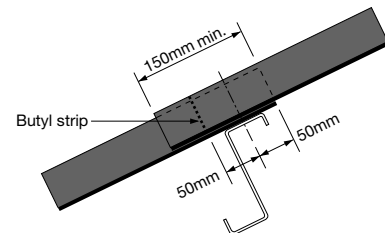

10 EASY STEPS TO FIXING

The fixing of a fibre cement roof can be accomplished by most people if they follow these ten easy steps in conjunction with the illustrations opposite. In order to weatherproof the roof, the butyl strip must be installed as described on page 21, and mitres cut to avoid having four thicknesses of sheeting in the same plane at the junctions of side and end laps.

- 1 Lay sheet number 1 at the eaves without mitring.
- 2 Lay sheet number 2, mitring bottom right hand corner as per the illustration opposite.
- 3 Lay sheet number 3, mitring as per step 2. Continue up the roof slope to complete the first tier.
- 4 Lay sheet number 4 at the eaves of the next tier, mitring the top left hand corner as per the illustration opposite.
- 5 Lay sheet number 5, mitring both top left hand and bottom right hand corners as per illustration opposite, and continue up the slope until ready to lay sheet number 6 at the ridge.
- 6 Lay sheet number 6 at the ridge, mitred as per step 2.
- 7 Repeat the procedure from and including step 4, working across the roof from eaves to ridge, until there is room for only one more tier to be laid, on the right hand edge.
- 8 Lay sheet number 7, mitring the top left hand corner. If necessary, reduce the sheet width by cutting down the right hand edge. All subsequent sheets in this final tier should be cut accordingly.
- 9 Lay sheet number 8 as per step 7, continuing up the roof slope until ready to lay the final sheet at the ridge.
- 10 Lay sheet number 9 at the ridge without mitring to complete the roof.

Notes:

- 1 On a duo pitch roof start both slopes from the same end of the building. One slope will therefore be sheeted left to right, the opposite slope will be sheeted right to left.
- 2 The corrugations of sheets must line up at the apex to ensure that the ridge accessories will fit.
- 3 When cranked crown sheets are used, both top courses of roofing sheets and the cranked crowns themselves must be mitred.
- 4 Always lay sheets with the correct end and side laps, as detailed elsewhere in this booklet.
- 5 Do not cut mitres in situ.

Mitring plan single slope roof

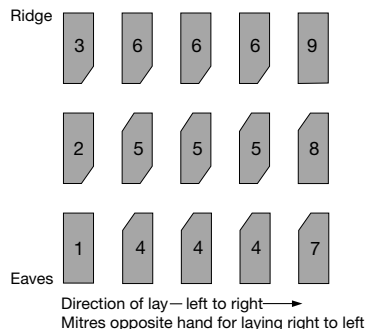

Mitring Profile 3*

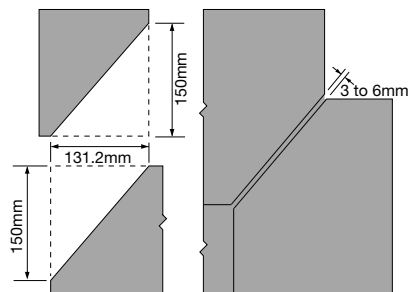

Mitring Profile 6*

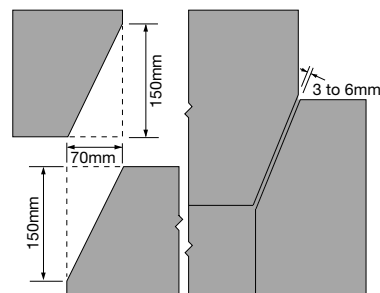

* Assumes 150mm end lap

WORKING WITH ETERNIT FIBRE CEMENT ROOFING SHEETS

Storage and handling

General

Profiled sheets should be stored as close as practically possible to the area of works, on a firm level base, using the profiled bearers (on which the sheets are delivered) to raise the sheets off the ground. Sheeting stacks should generally not exceed 1200mm high unless a level concrete base is available, in which case the maximum height is 1500mm. A separate stack should be made of each length of sheet; if this is not possible, stack with longest sheets at the bottom and the shortest at the top. It is important when stacking Profile 6 sheets on site that the smaller 'under rolls' are all on the same side of the stack. Sheets should always be stored weather (smooth) side upwards.

Stacks of sheets should not be stored in full sun during the summer months as the differential temperature across the sheets can result in unacceptable stresses in the sheets and can lead to edge cracking.

If sheets are to be retained in the packs for more than 3 months, they should be stored inside a building where they can be protected from extreme variations in temperature and moisture.

Ingress of moisture into packs of profiled sheets may cause efflorescence staining, bowing during installation or permanent distortion.

When handling sheets, lift by the ends only.

Natural Grey sheets

The plastic wrapping should be retained for as long as possible to control the environment around the sheets. Once the pack has been opened, or if the wrapping is damaged and allowing the ingress of water, the sheets should be stored under cover.

Coloured sheets

Coloured sheets should be stored under cover at all times, preferably inside a building, but if this is not available they can be stored under a tarpaulin. The tarpaulin should be spaced off the top and sides of the sheets to allow effective air circulation and avoid condensation.

The plastic wrapping on coloured sheets is only designed to protect the sheets in transit. It should be removed and carefully disposed of as soon as possible.

Working

When cutting fibre cement sheets, try to eliminate the exposure to dust (refer to Eternit Health and Safety data sheet).

Preferably sheets should be cut at ground level on suitable rigid supports using hand or powered saws. Powered saws should be of the reciprocating saw type and NOT disc or circular blade devices.

Preparation

Prior to sheeting, a responsible person should check that all purlins and rails are connected securely. Measurements should be taken to ensure that the structure and purlins are true and level to receive the sheeting. In particular, a check should be made that the purlins are spaced correctly for the right end lap, and that the eaves purlin provides an overhang into the gutter not exceeding 350mm (Profile 6) and 250mm (Profile 3). When the sheeting layout is being planned, care should be taken to ensure that the verge sheets are cut so that the outside edge coincides with a crown rather than a trough in the corrugations. This enhances the weather protection and can reduce the width of the flashings.

CDM Regulations

Specifiers have an obligation under the Construction (Design and Management) Regulations 2015 to identify and evaluate the health and safety implications of all products and construction methods required by their design.

Installation

The following guidelines should always be observed:

- Sheets should be installed smooth surface up.
- All fixing holes should be drilled, not punched, and adequate clearance (2mm minimum) provided for the fixing shank.
- There should be two fixings per sheet per purlin or fixing rail at the point shown on pages 10 and 11.
- Always lay the sheets in vertical tiers from the eaves to the ridge.
- Always fix sheets fully before moving on.
- To minimise dust, cut sheets with a handsaw or slow speed reciprocating power saw. The use of angle grinders is not recommended.
- Avoid deflecting a sheet whilst attempting to force a bearing.
- Do not step on side lap corrugations.
- Where regular access is required to reach roof lights, ventilation and service ducts, properly constructed walkways should be provided.

See back cover for 'Safety at Work'.

Safety at work

The recommendations of HSG 33 should be followed at all times:

- A safe place of work should be provided.
- Health and Safety Provisions should comply with current regulations and be suitable for working at height. The use of safety nets as fall arrest equipment should always be considered.
- Profile 6 sheets, when new and first installed in accordance with our recommendations, can be classified as a non-fragile Class C roof assembly in accordance with ACR[M]001. Once the roof has been completed and the netting/scaffolding removed, if any subsequent access is required on the roof, the sheets should be treated as a fragile assembly.
- Always use HSE recommended roof access systems whenever required.

Visit our website to see P6 & P3

- > Case Studies & Inspiration
- > Technical Product Information
- > Brochures and Technical PDFs

Email infouk@etexgroup.com
Or visit eternit.co.uk

Etex [Exteriors] UK, Wellington Road,
Burton-upon-Trent, Staffordshire DE14 2AA